

Cm

C_s^3

m

Monoclinic

No. 8

$C1m1$

Patterson symmetry $C12/m1$

UNIQUE AXIS b , CELL CHOICE 1

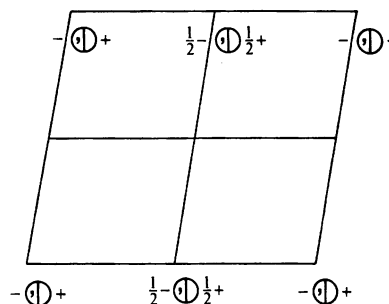
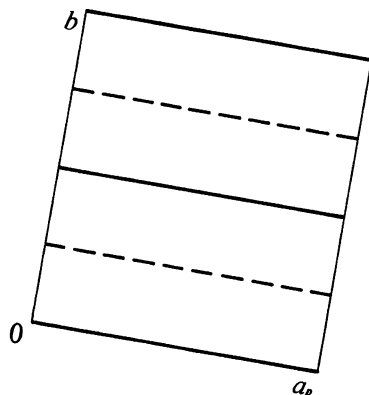
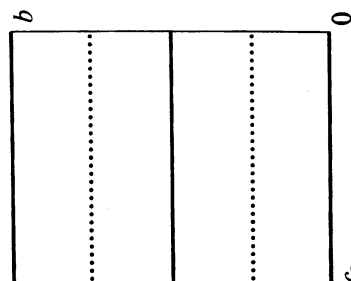
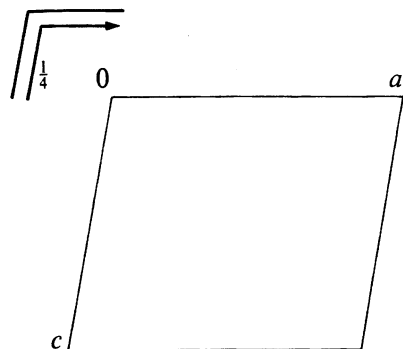

Origin on mirror plane m

Asymmetric unit $0 \leq x \leq 1; 0 \leq y \leq \frac{1}{4}; 0 \leq z \leq 1$

Symmetry operations

For $(0,0,0)+$ set

- (1) 1 (2) $m \ x,0,z$

For $(\frac{1}{2},\frac{1}{2},0)+$ set

- (1) $t(\frac{1}{2},\frac{1}{2},0)$ (2) $a \ x,\frac{1}{4},z$

Generators selected (1); $t(1,0,0)$; $t(0,1,0)$; $t(0,0,1)$; $t(\frac{1}{2},\frac{1}{2},0)$; (2)

Positions

Multiplicity, Wyckoff letter, Site symmetry		Coordinates		Reflection conditions
		$(0,0,0)+$	$(\frac{1}{2},\frac{1}{2},0)+$	General:
4	<i>b</i> 1	(1) x,y,z	(2) x,\bar{y},z	$hkl : h+k=2n$ $h0l : h=2n$ $0kl : k=2n$ $hk0 : h+k=2n$ $0k0 : k=2n$ $h00 : h=2n$
2	<i>a</i> <i>m</i>	$x,0,z$		Special: no extra conditions

Symmetry of special projections

Along [001] $c11m$
 $\mathbf{a}' = \mathbf{a}_p$ $\mathbf{b}' = \mathbf{b}$
 Origin at 0,0,z

Along [100] $p1m1$
 $\mathbf{a}' = \frac{1}{2}\mathbf{b}$ $\mathbf{b}' = \mathbf{c}_p$
 Origin at $x,0,0$

Along [010] $p1$
 $\mathbf{a}' = \mathbf{c}$ $\mathbf{b}' = \frac{1}{2}\mathbf{a}$
 Origin at 0,y,0

Maximal non-isomorphic subgroups

- I** [2] $C1(P1, 1)$ 1+
- IIa** [2] $P1a1(Pc, 7)$ 1; $2+(\frac{1}{2},\frac{1}{2},0)$
 [2] $P1m1(Pm, 6)$ 1; 2
- IIb** [2] $C1c1(\mathbf{c}' = 2\mathbf{c})(Cc, 9)$; [2] $I1c1(\mathbf{c}' = 2\mathbf{c})(Cc, 9)$

Maximal isomorphic subgroups of lowest index

- IIc** [2] $C1m1(\mathbf{c}' = 2\mathbf{c}$ or $\mathbf{a}' = \mathbf{a} + 2\mathbf{c}, \mathbf{c}' = 2\mathbf{c})(Cm, 8)$; [3] $C1m1(\mathbf{b}' = 3\mathbf{b})(Cm, 8)$

Minimal non-isomorphic supergroups

- I** [2] $C2/m(12)$; [2] $Cmm2(35)$; [2] $Cmc2(36)$; [2] $Amm2(38)$; [2] $Aem2(39)$; [2] $Fmm2(42)$; [2] $Imm2(44)$; [2] $Ima2(46)$;
 [3] $P3m1(156)$; [3] $P31m(157)$; [3] $R3m(160)$
- II** [2] $P1m1(\mathbf{a}' = \frac{1}{2}\mathbf{a}, \mathbf{b}' = \frac{1}{2}\mathbf{b})(Pm, 6)$

Cm C_s^3 m

Monoclinic

No. 8

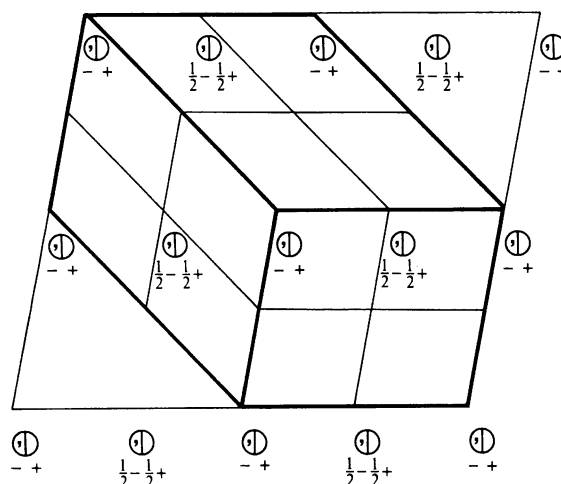
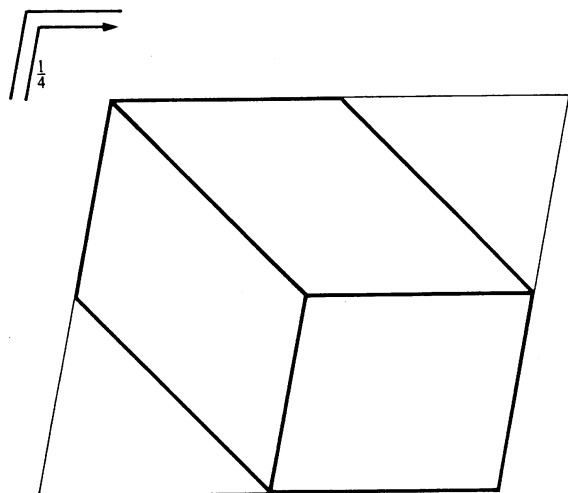
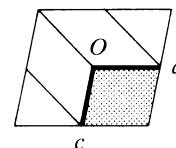
UNIQUE AXIS b , DIFFERENT CELL CHOICES $C1m1$ UNIQUE AXIS b , CELL CHOICE 1**Origin** on mirror plane m **Asymmetric unit** $0 \leq x \leq 1$; $0 \leq y \leq \frac{1}{2}$; $0 \leq z \leq 1$ **Generators selected** (1); $t(1,0,0)$; $t(0,1,0)$; $t(0,0,1)$; $t(\frac{1}{2}, \frac{1}{2}, 0)$; (2)**Positions**

Multiplicity, Wyckoff letter, Site symmetry	Coordinates
	$(0,0,0) + (\frac{1}{2}, \frac{1}{2}, 0) +$

4	b	1	(1) x, y, z	(2) x, \bar{y}, z
---	-----	---	---------------	---------------------

2	a	m	$x, 0, z$
---	-----	-----	-----------

Reflection conditions

General:

 hkl : $h + k = 2n$ $h0l$: $h = 2n$ $0kl$: $k = 2n$ $hk0$: $h + k = 2n$ $0k0$: $k = 2n$ $h00$: $h = 2n$

Special: no extra conditions

A 1 m 1UNIQUE AXIS *b*, CELL CHOICE 2**Origin** on mirror plane *m***Asymmetric unit** $0 \leq x \leq 1; 0 \leq y \leq \frac{1}{4}; 0 \leq z \leq 1$ **Generators selected** (1); $t(1,0,0)$; $t(0,1,0)$; $t(0,0,1)$; $t(0, \frac{1}{2}, \frac{1}{2})$; (2)**Positions**

Multiplicity, Wyckoff letter, Site symmetry		Coordinates
		$(0,0,0) + (0, \frac{1}{2}, \frac{1}{2}) +$

4	<i>b</i>	1	(1) x, y, z	(2) x, \bar{y}, z
---	----------	---	---------------	---------------------

2	<i>a</i>	<i>m</i>	$x, 0, z$
---	----------	----------	-----------

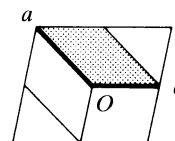

Reflection conditions

General:

$hkl : k + l = 2n$

$h0l : l = 2n$

$0kl : k + l = 2n$

$hk0 : k = 2n$

$0k0 : k = 2n$

$00l : l = 2n$

Special: no extra conditions

I 1 m 1UNIQUE AXIS *b*, CELL CHOICE 3**Origin** on mirror plane *m***Asymmetric unit** $0 \leq x \leq 1; 0 \leq y \leq \frac{1}{2}; 0 \leq z \leq 1$ **Generators selected** (1); $t(1,0,0)$; $t(0,1,0)$; $t(0,0,1)$; $t(\frac{1}{2}, \frac{1}{2}, \frac{1}{2})$; (2)**Positions**

Multiplicity, Wyckoff letter, Site symmetry		Coordinates
		$(0,0,0) + (\frac{1}{2}, \frac{1}{2}, \frac{1}{2}) +$

4	<i>b</i>	1	(1) x, y, z	(2) x, \bar{y}, z
---	----------	---	---------------	---------------------

2	<i>a</i>	<i>m</i>	$x, 0, z$
---	----------	----------	-----------

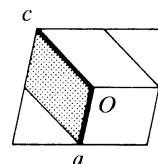

Reflection conditions

General:

$hkl : h + k + l = 2n$

$h0l : h + l = 2n$

$0kl : k + l = 2n$

$hk0 : h + k = 2n$

$0k0 : k = 2n$

$h00 : h = 2n$

$00l : l = 2n$

Special: no extra conditions

Cm

No. 8

 C_s^3 $A11m$ m

Monoclinic

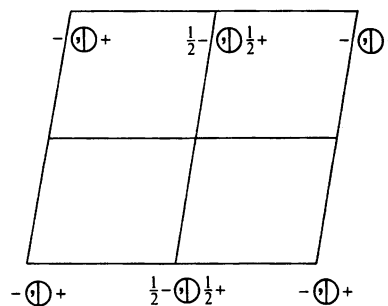
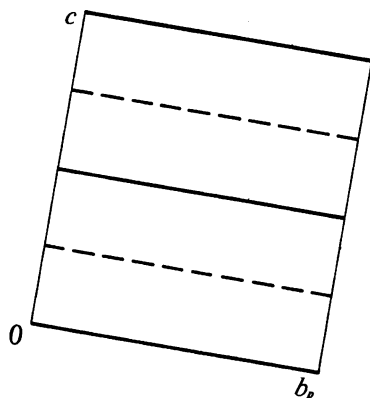
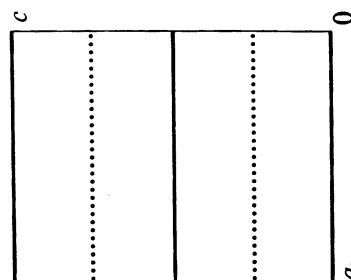
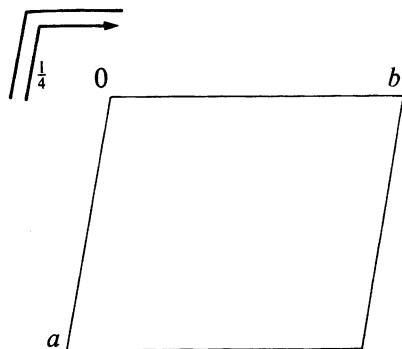
Patterson symmetry $A112/m$ UNIQUE AXIS c , CELL CHOICE 1**Origin** on mirror plane m **Asymmetric unit** $0 \leq x \leq 1; 0 \leq y \leq 1; 0 \leq z \leq \frac{1}{4}$ **Symmetry operations**For $(0,0,0)+$ set

- (1) 1 (2) m $x,y,0$

For $(0, \frac{1}{2}, \frac{1}{2})+$ set

- (1) $t(0, \frac{1}{2}, \frac{1}{2})$ (2) b $x,y, \frac{1}{4}$

Generators selected (1); $t(1,0,0)$; $t(0,1,0)$; $t(0,0,1)$; $t(0, \frac{1}{2}, \frac{1}{2})$; (2)

Positions

Multiplicity,
Wyckoff letter,
Site symmetry

Coordinates

$(0,0,0)+$ $(0, \frac{1}{2}, \frac{1}{2})+$

4 *b* 1

(1) x,y,z

(2) x,y,\bar{z}

Reflection conditions

General:

$hkl : k+l=2n$

$hk0 : k=2n$

$0kl : k+l=2n$

$h0l : l=2n$

$00l : l=2n$

$0k0 : k=2n$

Special: no extra conditions

2 *a* *m* $x,y,0$

Symmetry of special projections

Along $[001]$ $p1$

$\mathbf{a}' = \mathbf{a}$ $\mathbf{b}' = \frac{1}{2}\mathbf{b}$

Origin at $0,0,z$

Along $[100]$ $c11m$

$\mathbf{a}' = \mathbf{b}_p$ $\mathbf{b}' = \mathbf{c}$

Origin at $x,0,0$

Along $[010]$ $p1m1$

$\mathbf{a}' = \frac{1}{2}\mathbf{c}$ $\mathbf{b}' = \mathbf{a}_p$

Origin at $0,y,0$

Maximal non-isomorphic subgroups

I $[2]A1(P1, 1)$ $1+$

IIa $[2]P11b(Pc, 7)$ $1; 2 + (0, \frac{1}{2}, \frac{1}{2})$

$[2]P11m(Pm, 6)$ $1; 2$

IIb $[2]A11a(\mathbf{a}' = 2\mathbf{a})(Cc, 9)$; $[2]I11a(\mathbf{a}' = 2\mathbf{a})(Cc, 9)$

Maximal isomorphic subgroups of lowest index

IIc $[2]A11m(\mathbf{a}' = 2\mathbf{a}$ or $\mathbf{a}' = 2\mathbf{a}, \mathbf{b}' = 2\mathbf{a} + \mathbf{b})(Cm, 8)$; $[3]A11m(\mathbf{c}' = 3\mathbf{c})(Cm, 8)$

Minimal non-isomorphic supergroups

I $[2]C2/m(12)$; $[2]Cmm2(35)$; $[2]Cmc2_1(36)$; $[2]Amm2(38)$; $[2]Aem2(39)$; $[2]Fmm2(42)$; $[2]Imm2(44)$; $[2]Ima2(46)$;
 $[3]P3m1(156)$; $[3]P31m(157)$; $[3]R3m(160)$

II $[2]P11m(\mathbf{b}' = \frac{1}{2}\mathbf{b}, \mathbf{c}' = \frac{1}{2}\mathbf{c})(Pm, 6)$

Cm C_s^3 m

Monoclinic

No. 8

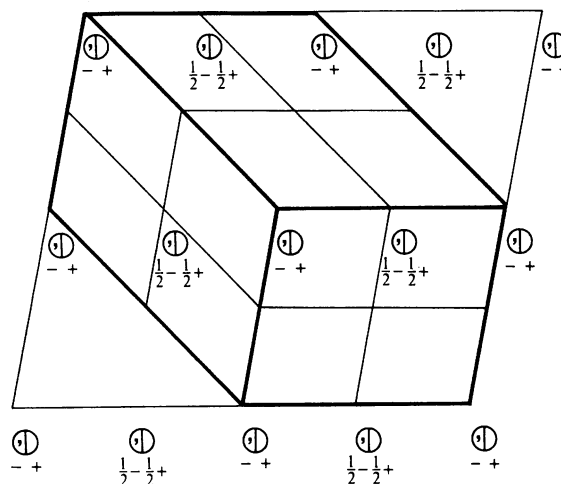
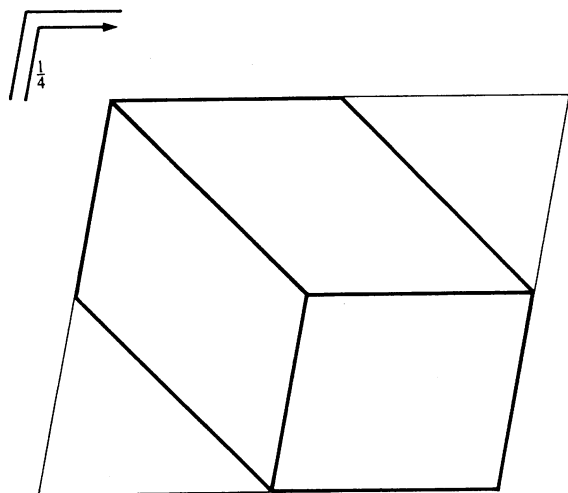
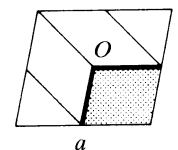
UNIQUE AXIS c , DIFFERENT CELL CHOICES $A11m$ UNIQUE AXIS c , CELL CHOICE 1**Origin** on mirror plane m **Asymmetric unit** $0 \leq x \leq 1; 0 \leq y \leq 1; 0 \leq z \leq \frac{1}{2}$ **Generators selected** (1); $t(1,0,0)$; $t(0,1,0)$; $t(0,0,1)$; $t(0, \frac{1}{2}, \frac{1}{2})$; (2)**Positions**

Multiplicity, Wyckoff letter, Site symmetry	Coordinates
	$(0,0,0) + (0, \frac{1}{2}, \frac{1}{2}) +$

4	b	1	(1) x, y, z	(2) x, y, \bar{z}
---	-----	---	---------------	---------------------

Reflection conditions

General:

 $hkl : k + l = 2n$ $hk0 : k = 2n$ $0kl : k + l = 2n$ $h0l : l = 2n$ $00l : l = 2n$ $0k0 : k = 2n$

Special: no extra conditions

2	a	m	$x, y, 0$
---	-----	-----	-----------

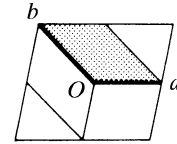
B11mUNIQUE AXIS c , CELL CHOICE 2**Origin** on mirror plane m **Asymmetric unit** $0 \leq x \leq 1; 0 \leq y \leq 1; 0 \leq z \leq \frac{1}{4}$ **Generators selected** (1); $t(1,0,0)$; $t(0,1,0)$; $t(0,0,1)$; $t(\frac{1}{2},0,\frac{1}{2})$; (2)**Positions**

Multiplicity, Wyckoff letter, Site symmetry		Coordinates
		$(0,0,0) + (\frac{1}{2},0,\frac{1}{2}) +$

4	b	1	(1) x,y,z	(2) x,y,\bar{z}
---	-----	---	-------------	-------------------

2	a	m	$x,y,0$
---	-----	-----	---------

Reflection conditions

General:

$hkl : h + l = 2n$

$hk0 : h = 2n$

$0kl : l = 2n$

$h0l : h + l = 2n$

$00l : l = 2n$

$h00 : h = 2n$

Special: no extra conditions

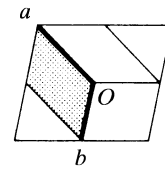
I11mUNIQUE AXIS c , CELL CHOICE 3**Origin** on mirror plane m **Asymmetric unit** $0 \leq x \leq 1; 0 \leq y \leq 1; 0 \leq z \leq \frac{1}{4}$ **Generators selected** (1); $t(1,0,0)$; $t(0,1,0)$; $t(0,0,1)$; $t(\frac{1}{2},\frac{1}{2},\frac{1}{2})$; (2)**Positions**

Multiplicity, Wyckoff letter, Site symmetry		Coordinates
		$(0,0,0) + (\frac{1}{2},\frac{1}{2},\frac{1}{2}) +$

4	b	1	(1) x,y,z	(2) x,y,\bar{z}
---	-----	---	-------------	-------------------

2	a	m	$x,y,0$
---	-----	-----	---------

Reflection conditions

General:

$hkl : h + k + l = 2n$

$hk0 : h + k = 2n$

$0kl : k + l = 2n$

$h0l : h + l = 2n$

$00l : l = 2n$

$h00 : h = 2n$

$0k0 : k = 2n$

Special: no extra conditions