

1.4. THERMAL EXPANSION

interference pattern IP is divided into two fields corresponding to the two ends of the sample. The difference of fringe movements within these two fields yields the absolute thermal expansion of the sample.

1.4.3.4. Electrical methods

1.4.3.4.1. Inductance changes (pushrod dilatometry)

With this method, the expansion of the crystal is transmitted out of the cooled or heated region to an external measuring device by a rod made of a reference material whose thermal expansion is low and well known (usually silica glass) (*cf.* Gaal, 1998). If this rod is inside a tube of the same material (silica glass), and the specimen is inside as well, then the difference in expansion between the crystal and an equal length of the reference material is measured. Above 1100 K, instead of silica glass, high-purity alumina or single-crystal sapphire or tungsten rods are used.

To measure the displacement of the rods, several techniques are used. The most important are:

(1) a ferrite core is moved in a coil to change the inductivity of the coil, which is detected by the change of resonance frequency of an electrical circuit having a fixed capacitance;

(2) linear-variable-differential transformers.

Temperature gradients in the rod and the tube can lead to severe complications. For every determination, the system should be calibrated by certified materials (White, 1998), such as α -Al₂O₃, Cu, Pt, fused silica, Si, W, Mg or Mo.

1.4.3.4.2. Capacitance methods

In a way similar to the interferometric methods, the change of the gap between the lower surface of P_1 and the upper surface of P_2 (Fig. 1.4.3.1) is used to determine the thermal expansion of the sample. This gap – with electrically conducting surfaces – is used as the capacitance in an electric circuit with a fixed inductance. The change of capacitance leads to a change of resonance frequency, which is measured.

1.4.4. Relation to crystal structure

The anharmonicities of the interatomic potentials gain importance with increasing vibration amplitudes of the atoms. Since, at a given temperature, weakly bonded atoms oscillate with larger amplitudes, they contribute to a larger degree to thermal expansion in comparison with stronger bonds. This correlation follows also from the Grüneisen relation (1.4.2.14) because α (or

β) is proportional to the compressibility, which, in turn, is a rough measure of the interatomic and intermolecular forces.

This simple consideration allows qualitative predictions of the thermal expansion behaviour of a crystal species if the structure is known:

(1) Covalent bonds are associated with very small thermal expansions (diamond, graphite perpendicular to the c axis), whereas van der Waals bonds give rise to large thermal expansions (N₂, graphite parallel to the c axis). In accordance with their relatively high elastic stiffness, hydrogen bonds, especially short hydrogen bonds, lead to comparably small thermal expansions.

(2) In layer-like structures, the maximum thermal expansion occurs normal to the layers (mica, graphite, pentaerythritol).

(3) Thermal expansion decreases when the density of weak bonds decreases; therefore, expansion is greater for crystals with small molecules (many van der Waals contacts per volume) than for their larger homologues (*e.g.* benzene–naphthalene–anthracene).

Buda *et al.* (1990) have calculated the thermal expansion of silicon by means of *ab initio* methods. It is to be expected that these methods, which are currently arduous, will be applicable to more complicated structures in the years to come and will gain increasing importance in this field (*cf.* Lazzeri & de Gironcoli, 1998).

It is observed rather frequently in anisotropic materials that an enhanced expansion occurs along one direction and a contraction (negative expansion) in directions perpendicular to that direction (*e.g.* in calcite). The volume expansion, *i.e.* the trace of α_{ij} , is usually positive in these cases, however. If the tensor of elastic constants is known, such negative expansions can mostly be explained by a lateral Poisson contraction caused by the large expansion (Küppers, 1974).

Only a few crystals show negative volume expansion and usually only over a narrow temperature range (*e.g.* Si and fused silica below about 120 K and quartz above 846 K) (White, 1993). Cubic ZrW₂O₈ was recently found to exhibit isotropic negative thermal expansion over the complete range of stability of this material (0.5–1050 K) (Mary *et al.*, 1996). This behaviour is explained by the librational motion of practically rigid polyhedra and a shortening of Zr–O–W bonds by transverse vibration of the oxygen atom. By tailoring the chemical content (of TiO₂ or

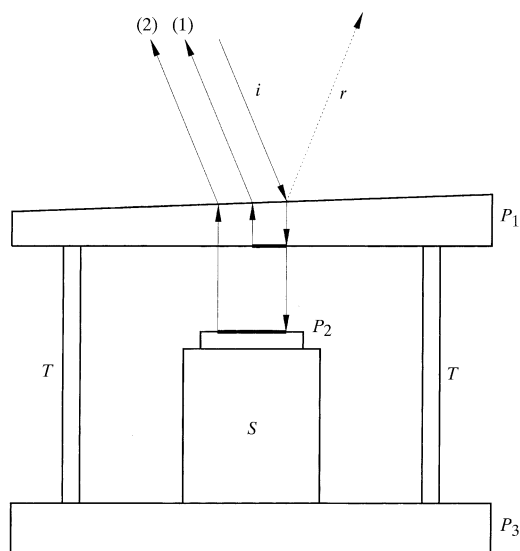

Fig. 1.4.3.1. Schematic diagram of a Fizeau interferometer.

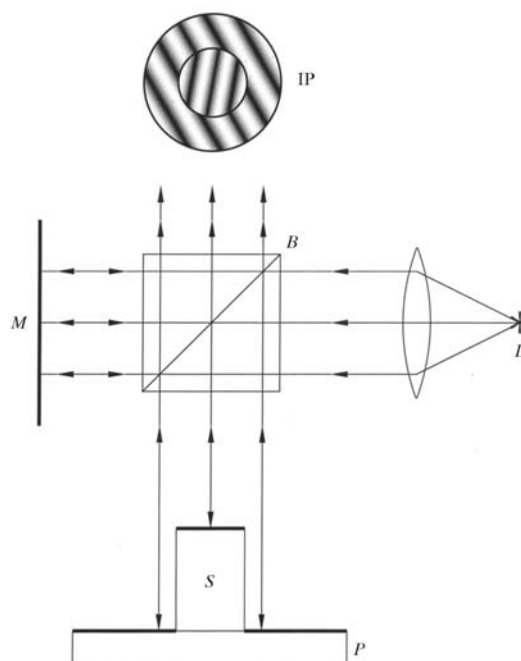

Fig. 1.4.3.2. Schematic diagram of a Michelson interferometer.